

BUCKEYE TRACTOR CO

PARTS CATALOG

Replacement • Accessory • Hardware • Kits

Revision 31-23

U-bolts

Clamps

Hilling Disks / Parts

Wear Parts

Water Wheels, Plant Punches & Plumbing

Drip Tape Applicator Components

Shovels, Sweeps, Hoes

Cultivator Attachments



BUCKEYE TRACTOR CO

P.O.Box 97 • 11313 Slabtown Road • Columbus Grove, Ohio 45830 USA

Call 419-659-2162 • Fax 419-659-2082

800-526-6791 • www.BucTraCo.com

YOUR PURCHASE INCLUDES COMPLETE AFTER-SALE SERVICE

U-BOLTS

HARDWARE

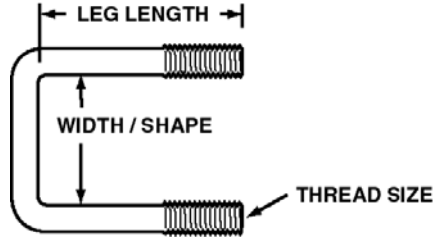

3/8

Part No	Thread	Width / Shape	Leg Length	For toolbar size	Wt.	Retail.Price	
10629	3/8-16	1-1/2" square	2-1/2"	1-1/2" x 1-1/2" sq	0.16.	2.60	
10633	3/8-16	2" square	2-7/8"	2" square	0.20	2.37	
10632	3/8-16	2" square	3-1/8"	2" square	0.21	5.62	
10646	3/8-16	2-1/2" square	3-3/8"	2-1/2" x 2-1/2" sq	0.24	3.67	
10645	3/8-16	2-1/2" square	3-5/8"	2-1/2" x 2-1/2" sq	0.25	NA	
11008	3/8-16 Hex Nut - price each						0.12

1/2

Part No	Thread	Width / Shape	Leg Length	For toolbar size	Wt.	Retail.Price	
11121	1/2-13	2" square	3"	2" square	0.38	2.92	
10739	1/2-13	2-1/2" square	3-1/2"	2-1/2" x 2-1/2" sq	0.45	3.96	
10741	1/2-13	3" square	3"	3" x 2" rectangle	0.44	4.76	
10730	1/2-13	3" square	4"	3" x 3" square	0.52	4.12	
10731	1/2-13	4" square	3"	4" x 2" rectangle	0.47	7.02	
10732	1/2-13	4" square	5"	4" x 4" square	0.65	5.20	
11051	1/2-13 Hex Nut - price each					0.036	0.24

U-BOLTS

HARDWARE

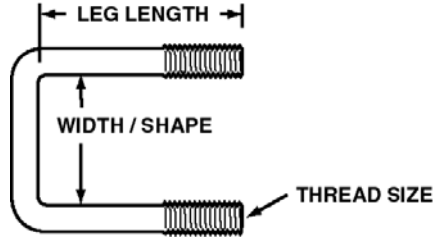

5/8

Part No	Thread	Width / Shape	Leg Length	For toolbar size	Wt.	Retail.Price
10700	5/8-11	2-1/2" square	4"	2-1/2" x 2-1/2" sq	0.78	9.22
11122	5/8-11	3" square	4-1/2"	3" x 3" square	0.89	8.71
10776	5/8-11	3" square	3-1/2"	3" x 2" rectangle	0.74	9.07
10737	5/8-11	4" square	5-1/2"	4" x 4" square	1.09	9.50
10684	5/8-11	6" square	7-1/2"	6" x 6" square	1.51	13.32
11142	5/8-11 Hex Nut - price each					0.45

3/4

Part No	Thread	Width / Shape	Leg Length	For toolbar size	Wt.	Retail.Price
11063	3/4-10	4" square	5-3/4"	4" x 4" square	1.68	14.18
11172	3/4-10 Hex Nut - price each					0.71

U-BOLTS

HARDWARE

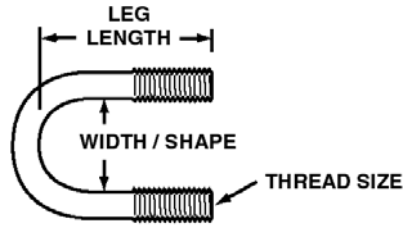

1/2

Part No	Thread	Width / Shape	Leg Length	For toolbar size	Wt.	Retail.Price
10714	1/2-13	1-1/4" round	2-1/2"	1-1/4" round	0.29	2.40
10718	1/2-13	1-1/2" round	2-3/4"	1-1/2" round	0.31	2.88
11051	1/2-13 Hex Nut - price each					0.24

ACCESSORY

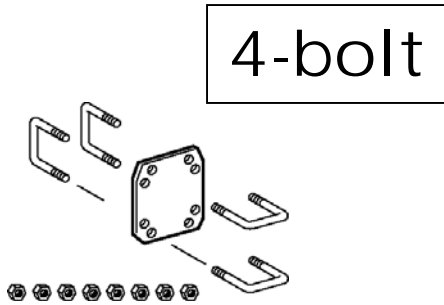

Part No	U-Bolt	Toolbar	U-Bolt	Shank/Perpendicular	Wt.	Retail.Price
20154-33	3/8-16	2" square	3/8-16	1-1/2" square	2.2	20.00
20204-33	3/8-16	2" square	3/8-16	2" square	2.6	21.00
20204-44	1/2-13	2" square	1/2-13	2" square	4.0	27.00
25154-33	3/8-16	2-1/2" square	3/8-16	1-1/2" square		24.00
25204-33	3/8-16	2-1/2" square	3/8-16	2" square	2.8	24.00
25204-44	1/2-13	2-1/2" square	1/2-13	2" square		30.00
25254-44	1/2-13	2-1/2" square	1/2-13	2-1/2" square		33.00
30204-44	1/2-13	3" square	1/2-13	2" square		32.00
30254-44	1/2-13	3" square	1/2-13	2-1/2" square		35.00
30304-44	1/2-13	3" square	1/2-13	3" square		37.00
40204-44	1/2-13	4" square	1/2-13	2" square	5.4	36.00
40254-44	1/2-13	4" square	1/2-13	2-1/2" square		40.00
40304-44	1/2-13	4" square	1/2-13	3" square		42.00
40404-44	1/2-13	4" square	1/2-13	4" square	7.5	47.00

Clamp assemblies also available with U-bolts for 3 x 2 and 4 x 2 rectangular toolbars

ACCESSORY

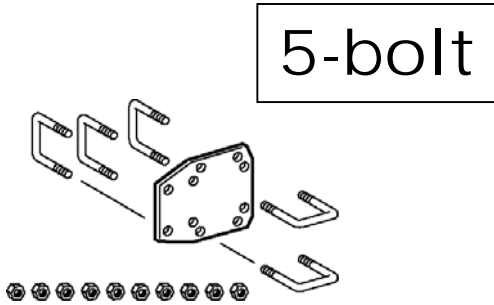

Part No	U-Bolt	Toolbar	U-Bolt	Shank/Perpendicular	Wt.	Retail.Price
20155-33	3/8-16	2" square	3/8-16	1-1/2" square	3.0	26.00
20205-44	1/2-13	2" square	1/2-13	2" square	5.4	34.00
20255-44	1/2-13	2" square	1/2-13	2-1/2" square	5.6	38.00
25155-33	3/8-16	2-1/2" square	3/8-16	1-1/2" square		31.00
25205-44	1/2-13	2-1/2" square	1/2-13	2" square	5.8	39.00
25255-44	1/2-13	2-1/2" square	1/2-13	2-1/2" square	6.4	42.00
30205-44	1/2-13	3" square	1/2-13	2" square		38.00
30255-44	1/2-13	3" square	1/2-13	2-1/2" square		44.00
40205-44	1/2-13	4" square	1/2-13	2" square		49.00

Clamp assemblies also available with U-bolts for 3 x 2 and 4 x 2 rectangular toolbars

CLAMPS

ACCESSORY

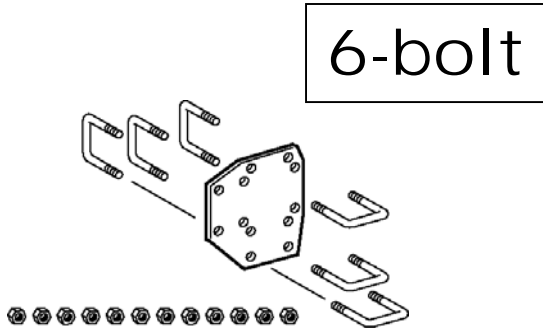

Part No	U-Bolt	Toolbar	U-Bolt	Shank/Perpendicular	Wt.	Retail.Price
20206-44	1/2-13	2" square	1/2-13	2" square		48.00
25256-44	1/2-13	2-1/2" square	1/2-13	2-1/2" square		56.00
30256-44	1/2-13	3" square	1/2-13	2-1/2" square		59.00
30256-44	1/2-13	3" square	1/2-13	3" square		62.00
40256-44	1/2-13	4" square	1/2-13	2-1/2" square		63.00
40306-44	1/2-13	4" square	1/2-13	3" square		71.00

Clamp assemblies also available with U-bolts for 3 x 2 and 4 x 2 rectangular toolbars or shanks

ACCESSORY

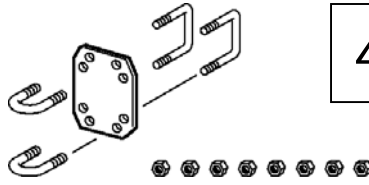

4-bolt

Part No	U-Bolt	Toolbar	U-Bolt	Shank/Perpendicular	Wt.	Retail.Price
20124-4R	1/2-13	2" square	1/2-13	1-1/4" round	3.4	24.00
20154-4R	1/2-13	2" square	1/2-13	1-1/2" round	3.6	26.00
25124-4R	1/2-13	2-1/2" square	1/2-13	1-1/4" round		26.00
25154-4R	1/2-13	2-1/2" square	1/2-13	1-1/2" round	3.8	29.00
30124-4R	1/2-13	3" square	1/2-13	1-1/4" round		28.00
30154-4R	1/2-13	3" square	1/2-13	1-1/2" round		30.00
40124-4R	1/2-13	4" square	1/2-13	1-1/4" round		31.00
40154-4R	1/2-13	4" square	1/2-13	1-1/2" round		34.00

Clamp assemblies also available with U-bolts for 3 x 2 and 4 x 2 rectangular toolbars

ACCESSORY

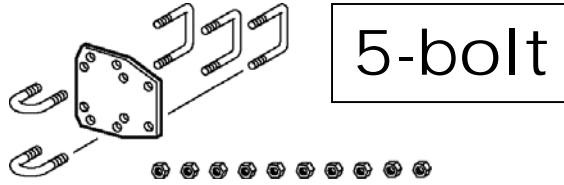

Part No	U-Bolt	Toolbar	U-Bolt	Shank/Perpendicular	Wt.	Retail.Price
20125-4R	1/2-13	2" square	1/2-13	1-1/4" round	4.4	30.00
20155-4R	1/2-13	2" square	1/2-13	1-1/2" round	4.6	32.00
25125-4R	1/2-13	2-1/2" square	1/2-13	1-1/4" round	4.8	35.00
25155-4R	1/2-13	2-1/2" square	1/2-13	1-1/2" round	5.2	36.00

Clamp assemblies also available with U-bolts for 3 x 2 and 4 x 2 rectangular toolbars

REPLACEMENT

Part No	Description	Weight	Retail.Price
19214	Complete Hub Asby	2.4	53.00
16768	Bearing, 204RY2, John Deere AA21480		13.98
18894	Disk & Hub Asby (assembled)	6.6	79.00
16769	Disk Blade, 14" - 6-bolt x 2-7/8" circle for 1/4" fasteners	5.2	26.70
16764	Shank 1-1/4" diameter x approx 20" long	6.8	36.78
99014FA	Fasteners for Disk Hex Capscrew, 5/8-11 x 3-1/4	0.55	9.15
for 1721 - 1921 - 2111 - 1912 - 2112 - 1723 - 1923 - 2113 - 2123 - 2133 - 2233 - 2333 - 4133 - 1914 - 1917			
00114	Disk, 14" & Shank (no clamp)	14.0	100.00
20114	Disk, 14", Shank & Clamp for 2" sq toolbar	18.4	121.00
25114	Disk, 14", Shank & Clamp for 2-1/2" sq toolbar	18.8	122.00

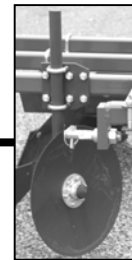



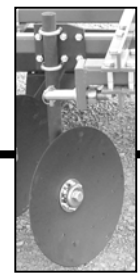
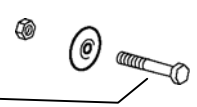
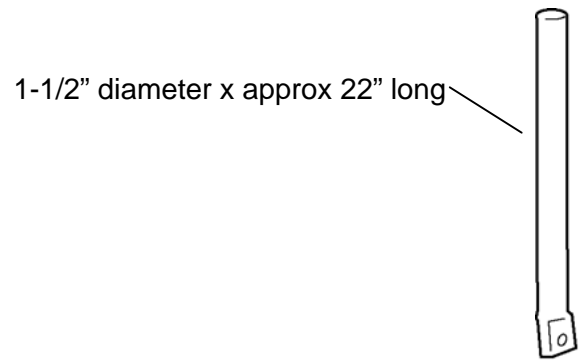
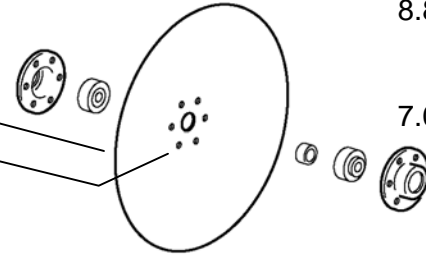
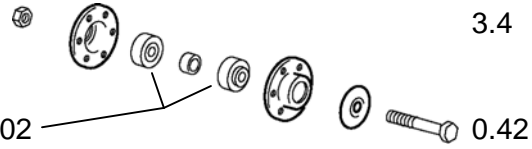

REPLACEMENT

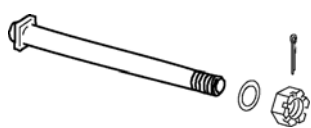

Part No	Description	Weight	Retail.Price
19216	Complete Hub Asby	3.4	59.00
17919	Bearing, 205RVA, John Deere A27002	0.42	
19296	Disk & Hub Asby (assembled)	8.8	92.00
17910	Disk Blade, 16" - 6-bolt x 3" circle for 5/16" fasteners	7.0	33.58
17837	Shank 1-1/2" diameter x approx 22" long	10.8	53.00
99016FA	Fasteners for Disk Hex Capscrew, 3/4-10 x 3-3/4	0.81	10.61
for 2321 - 4321 - 4333 - 2212 - 2412 - 4412 - 2537 (early)			
00116	Disk, 16" & Shank (no clamp)	20.5	124.00
20116	Disk, 16", Shank & Clamp for 2" sq toolbar	25.0	150.00
25116	Disk, 16", Shank & Clamp for 2-1/2" sq toolbar	25.5	151.00

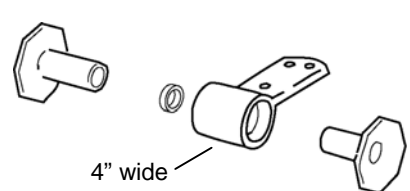
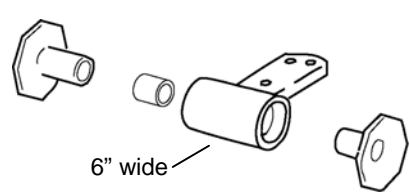

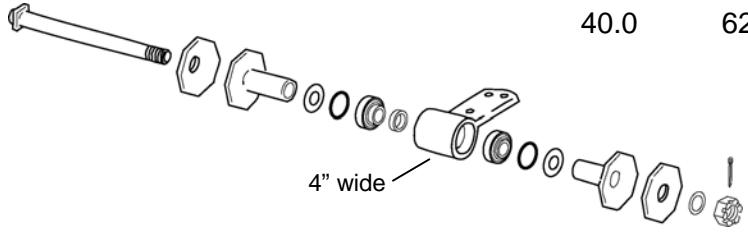
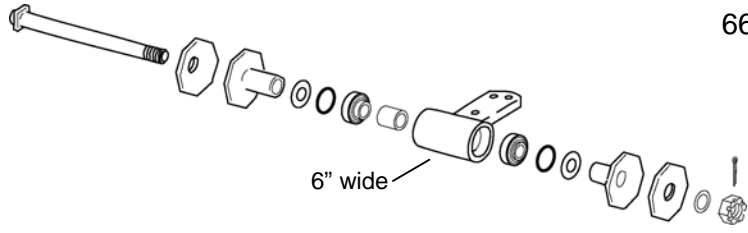

REPLACEMENT

Part No	Description	Weight	Retail Price	
14490	Arbor, 1-1/2rd x 18-1/2"		98.67	
10738	Hex Slotted Nut, 1-1/2-12		7.55	
11150	Machine Bushing, 1-1/2-10ga		3.96	
11138	Cotter pin, 1/4 x 2		0.35	
length for 2-blade gangs with 14" blade spacing				
18101	[Bearing Shield] Flat Washer, 1-3/8 SAE for 1-1/2 shaft - <i>quantity (2) ea gang</i>		1.44	
18102	[Rubber Spacer] O-Ring - <i>quantity (2) in each gang assembly</i>		2.37	
18089	Bearing, SER208-24 (discard snap ring and set screws) - <i>quantity (2) ea gang</i>	1.66	36.75	
				
14491	End Washer, Concave		2.6	30.36
18583	Half Spool, Flat	 <p>4" wide</p>	57.68	
18088	Bearing Spacer, 2-9/16"		3.00	
14884	Bearing Housing		252.00	
18581	Half Spool, Concave		63.75	
length for 2-blade gangs with 14" blade spacing				
18693	Half Spool, Flat	 <p>6" wide</p>	56.16	
18251	Bearing Spacer, 2-9/16"		8.18	
18288	Bearing Housing		287.00	
18691	Half Spool, Concave		62.23	
length for 2-blade gangs with 14" blade spacing				
14493	End Washer, Flat		2.6	24.48

REPLACEMENT

Part No	Description	Weight	Retail.Price
18082	Gang Hub & Spool Asby 	40.0	623.00
18184	Gang Hub & Spool Asby 		660.00
17237	Disk Blade, 16" Notched 		39.00
17741	Disk Blade, 18" Notched		43.00
14677	Disk Blade, 20" Notched		58.00
15046	Disk Blade, 22" Notched		62.00
18044	Disk Blade, 24" Notched		89.00
18549	Disk Blade, 26" Notched		134.00

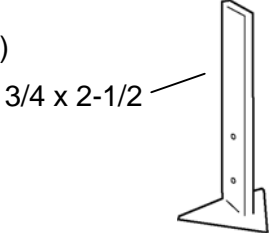
REPLACEMENT

Part No	Description	Weight	Retail.Price
17279	Furrow Shank & Shovel - Bed Shaper - 1921 (thru 9-2007)		NA
			
18470	Furrow Shank - Bed Shaper - 1921 (10-2007 and after)	13.6	85.56
99002FP	Bag of Shear Bolts includes (6) 1/2 x 2-1/2 all-thread shear bolts w/ nuts		6.00
00021FA	Bag of Fasteners - to install Flat-Mount Shovel includes (3) 5/16-18 x 1 hex capscrew w/ nuts		1.00
16520	Flat-Mount Shovel, 9"	2.1	36.00
17526	Furrow Shank, 1 x 3 Furrow Shank, 1-1/4 x 3 - Bed Shaper - 2121 - 2321 - 2331 - Raisde Bed Mulch Layers - 2122 - Toolbar Cultivators - 2x60 - 2x70		NA 145.73
99002FP	Bag of Shear Bolts includes (6) 1/2 x 2-1/2 all-thread shear bolts w/ nuts		6.00
00022FA	Bag of Fasteners - to install Flat-Mount Shovel includes (3) 3/8-16 x 1 hex capscrew w/ nuts		2.00
18736	Flat-Mount Shovel, 10"	5.8	43.00
18837	Flat-Mount Shovel, 12"	6.6	46.00
17521C	Flange, 3-hole, WELD-ON - for 18736 or 18837 Flat-Mount Shovel		8.00
			

REPLACEMENT

Part No	Description	Weight	Retail.Price
18483	Furrow Shank Bottom, 1-1/4 x 2-1/2, 3/8 shear-bolt - Bed Shapers - 4321 - Raised Bed Mulch Layers - 4412 - 4422 - Toolbar Cultivators - 4x60 - 4x70	13.2	144.40
99001FP	Bag of Shear Bolts includes (6) 3/8 x 2-1/2 all-thread shear bolts w/ nuts		5.00
00022FA	Bag of Fasteners - to install Flat-Mount Shovel includes (3) 3/8-16 x 1 hex capscrews w/ nuts		2.00
18736	Flat-Mount Shovel, 10"	5.8	43.00
18837	Flat-Mount Shovel, 12"	6.6	46.00
19793	Furrow Shank Bottom, 1-1/4 x 2-1/2, 7/16 shear bolt - Bed Shapers - 4521 - 4531 - Raised Bed Mulch Layers - 4612	13.0	141.40
99023FP	Bag of Shear Bolts includes (6) 7/16 x 2-1/2 all-thread shear bolts w/ nuts		6.00
00021FA	Bag of Fasteners - to install Flat-Mount Shovel includes (3) 3/8-16 x 1 hex capscrews w/ nuts		2.00
18736	Flat-Mount Shovel, 10"	5.8	43.00
18837	Flat-Mount Shovel, 12"	6.6	46.00

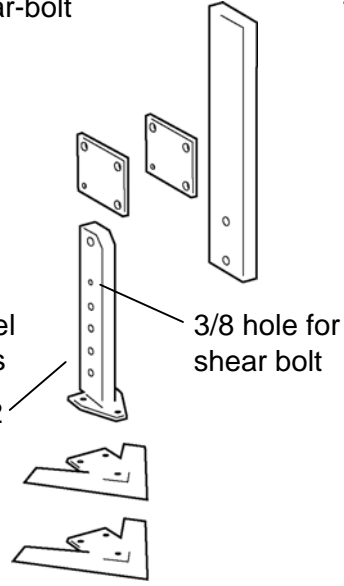

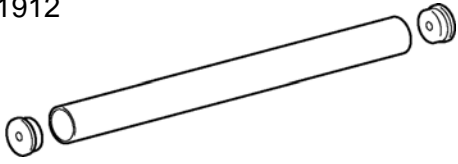
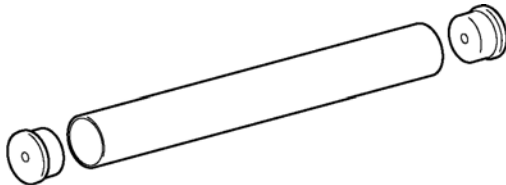

MULCH LAYERS

REPLACEMENT

Part No	Description	Weight	Retail.Price
18114	End Bearing, UHMW - for 1/2" spindle (7/16 shaft) - drill out hole to 9/16" for older 1/2" shaft - Mulch Layers - 1723 - 1913 - 1923 - Raised Bed Mulch Layers - 1912		16.00
142360	Roller Pipe, 2 x 36		20.00
142420	Roller Pipe, 2 x 42		23.00
142480	Roller Pipe, 2 x 48		25.00
142540	Roller Pipe, 2 x 54		28.00
16116	End Bearing, Oiled Wood - for 5/8" spindle (9/16 shaft) - drill out hole to 11/16" for older 5/8" shaft - Mulch Layers - 2113 - 2123 - 2133 - 2233 - 2333 - Raised Bed Mulch Layers - 2112 - 2212 - 4412 - 4422 - 4612		18.00
153360	Roller Pipe, 3 x 36		25.00
153420	Roller Pipe, 3 x 42		29.00
153480	Roller Pipe, 3 x 48		32.00
153540	Roller Pipe, 3 x 54		36.00
153600	Roller Pipe, 3 x 60		40.00
153660	Roller Pipe, 3 x 66		44.00
153720	Roller Pipe, 3 x 72		47.00

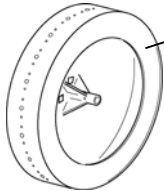
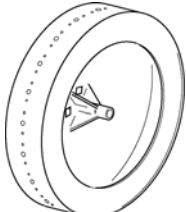
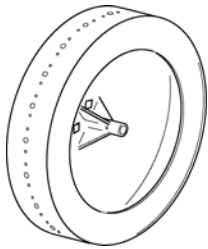
ACCESSORY

Part No	Description		Retail Price	
Small Water Wheel Systems - recommended maximum 2 x 3 punch size				
26005	Water Wheel Pkg, 60 x 5	 <p>double panel</p>	208.00	
26010	Water Wheel Pkg, 60 x 10		NA	
26605	Water Wheel Pkg, 66 x 5-1/2		219.00	
27204	Water Wheel Pkg, 72 x 4		230.00	
27206	Water Wheel Pkg, 72 x 6		226.00	
27208	Water Wheel Pkg, 72 x 8		226.00	
27209	Water Wheel Pkg, 72 x 9		230.00	
27212	Water Wheel Pkg, 72 x 12	NA		
Medium Water Wheel Systems - recommended maximum 2-1/2 x 4 punch size				
28004	Water Wheel Pkg, 80 x 4		239.00	
28005	Water Wheel Pkg, 80 x 5		234.00	
28104	Water Wheel Pkg, 81 x 4-1/2		231.00	
28109	Water Wheel Pkg, 81 x 9		NA	
28403	Water Wheel Pkg, 84 x 3-1/2		239.00	
28407	Water Wheel Pkg, 84 x 7		NA	
Large Water Wheel Systems - recommended maximum 3 x 5 punch size				
29005	Water Wheel Pkg, 90 x 5		331.00	
29022	Water Wheel Pkg, 90 x 22		332.00	
29612	Water Wheel Pkg, 96 x 12		358.00	
30217	Water Wheel Pkg, 102 x 17		368.00	
30827	Water Wheel Pkg, 108 x 27		387.00	
Large Water Wheel Systems w/ Wide-Base Punches - recommended maximum 4 x 6 punch size please inquire			Water Wheel "Packages" include (2) shaft collars, fasteners for plant punches and hole caps	

17712	Plant Punch, 1-1/2 x 2 Pointed		0.34	3.00
17723	Plant Punch, 2 x 3 Pointed		0.60	4.00
17724	Plant Punch, 2-1/2 x 4 Pointed		0.94	5.00
17735	Plant Punch, 3 x 5 Pointed		1.34	8.00

ACCESSORY

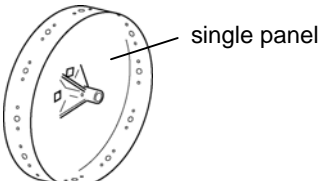
Part No	Description		Retail Price
Small Dry Systems - recommended maximum 2 x 3 punch size			
20605	Dry Wheel Pkg, 60 x 5		142.00
20665	Dry Wheel Pkg, 66 x 5-1/2		148.00
20724	Dry Wheel Pkg, 72 x 4		154.00
20726	Dry Wheel Pkg, 72 x 6		147.00
20729	Dry Wheel Pkg, 72 x 9		152.00

Medium Dry Wheel Systems - recommended maximum 2-1/2 x 4 punch size





20804	Dry Wheel Pkg, 80 x 4		160.00
20805	Dry Wheel Pkg, 80 x 5		154.00
20814	Dry Wheel Pkg, 81 x 4-1/2		158.00
28403	Dry Wheel Pkg, 84 x 3-1/2		162.00

Dry Wheel "Packages" include (2) shaft collars, fasteners for plant punches and hole caps



17702	Plant Punch Stud		2.00
-------	------------------	--	------

17712	Plant Punch, 1-1/2 x 2 Pointed		0.34	3.00
17723	Plant Punch, 2 x 3 Pointed		0.60	4.00
17724	Plant Punch, 2-1/2 x 4 Pointed		0.94	5.00

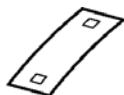
ACCESSORY



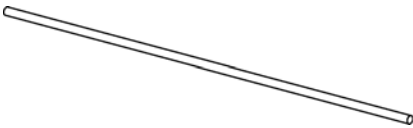

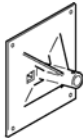
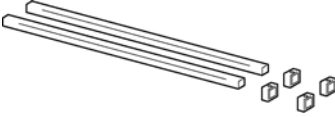
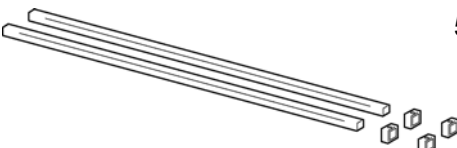
Part No	Description		Retail Price
00024FA	Fastener Bag for Plant Punches - for DRY WHEELS with up to 12 punches - (25) 5/16 x 3/4 Carriage Bolts & Nuts, both Zinc Plated - (12) Water Hole Cap, #120120		17.00
00048FA	Fastener Bag for Plant Punches - for DRY WHEELS with up to 24 punches - (50) 5/16 x 3/4 Carriage Bolts & Nuts, both Zinc Plated - (24) Water Hole Cap, #120120		22.00
00124FA	Fastener Bag for Plant Punches - for WATER WHEELS with up to 12 punches - (25) 5/16 x 3/4 Carriage Bolts, Stainless & Nuts, Zinc Plated - (12) Water Hole Cap, #120120		38.00
00148FA	Fastener Bag for Plant Punches - for WATER WHEELS with up to 24 punches - (50) 5/16 x 3/4 Carriage Bolts, Stainless & Nuts, Zinc Plated - (24) Water Hole Cap, #120120		65.00
120120	Water Hole Cap, 5/8		1.25
17420	Water Hole Cap - for older planter models (2000-2014)		2.00

ACCESSORY

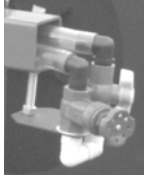
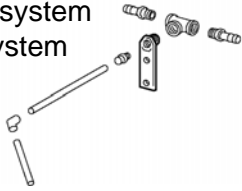

Part No	Description		Weight	Retail.Price
17897	Shaft, 1 x 36 Stainless or Chrome		5.1	97.00
17931	Shaft, 1 x 48 Stainless or Chrome		6.8	127.00
16185	Shaft Collar, 1"		0.22	5.49
11118	Hex Capscrew, 5/16 x 1/2			0.20
17941	Water Wheel Hub - for older planter models (2000-2014)		6.8	69.92
17720	Timing Bar Pkg, 30"		4.5	39.00
17880	Timing Bar Pkg, 42"		5.9	41.00

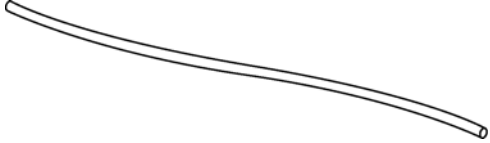
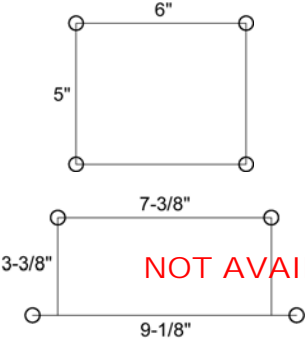
WATER WHEEL PLANTERS



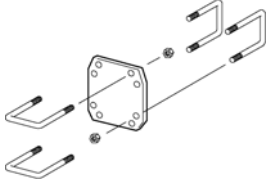
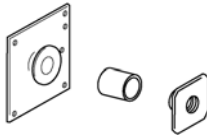

ACCESSORY

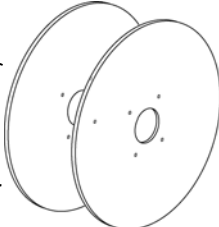
Part No	Description		Retail Price	
18634	Valve & Plumbing Asby - includes hose, 3/4" -- for Models 1716, 1816 (both 2014-)		135.00	
19734	Valve & Plumbing Asby - includes hose, 1" -- for Models 2216, 2326, 4416, 4526 (all 2014-)		146.00	
18034	Additional Modular Tee Asby - for 3/4" hose system		28.00	
19039	Additional Modular Tee Asby - for 1" hose system		31.00	
18007	Base Modular Tee Asby - for 3/4" hose system		26.00	
19011	Base Modular Tee Asby - for 1" hose system		29.00	
19406B	Hose, 3/4" Nylon - for Models 1716, 1816, 2216 (2000-2014)		per ft 3.00	
19408B	Hose, 1" Nylon - for Models 2216 (2014-), 2326 (2014-), 4416, 4526, 4626		per ft 3.50	
				
18280	Seat	 6" (width), 5" (height) for top seat; 7-3/8" (width), 3-3/8" (height) for bottom seat; 9-1/8" (width) for bottom seat.	10.5	150.00
		 NOT AVAILABLE		



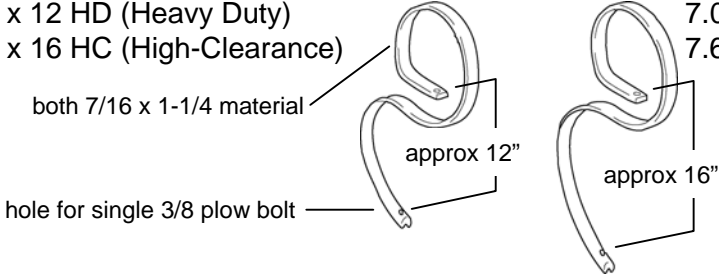

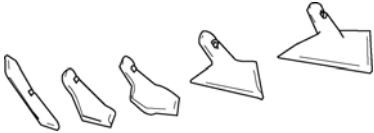
REPLACEMENT & ACCESSORY

Part No	Description		Retail Price	
16874	Shank & Shoe (no clamp)		9.4	94.00
20288	Shank & Shoe w/ Clamp - for 2" square toolbar		15.0	110.00
25288	Shank & Shoe w/ Clamp - for 2-1/2" square toolbar		15.5	112.00
Clamps for above 16874 Shank & Shoe				
20204-33	Clamp Asby, 2sq x 2sq		2.6	21.00
25204-33	Clamp Asby, 2-1/2sq x 2sq		2.8	24.00
16271	Spool Driver, Outside		2.2	25.80
16276	Spool Nut, RH thread - for 1925-T, 2125-TB		0.43	12.14
17677	Spool Nut, LH thread - for 1925-TL, 2125-TBL		0.43	14.15
16281	Nut Sleeve, 2"		0.09	1.38
15058	Pulley, 4"			15.00
16666	Brake Belt		0.50	44.45
16861	Tape Roll Caps	 <p>includes (2) roll caps and fasteners for (1) tape applicator</p>	15.5	58.00

REPLACEMENT & ACCESSORY

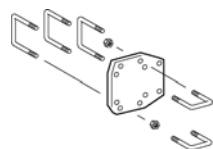
Part No	Description		Retail Price	
20123	S-Tine Clamp - for 2" square toolbar		2.1	16.00
25123	S-Tine Clamp - for 2-1/2" square toolbar		2.3	20.00
11550	S-Tine, 7/16 x 1-1/4 x 12 HD (Heavy Duty)		7.0	34.00
12843	S-Tine, 7/16 x 1-1/4 x 16 HC (High-Clearance)		7.6	58.00
00013FA	Bag of Fasteners for Shovel - (1) 3/8-16 x 1-1/2 Plow Bolt with Washer and Nut		0.75	
11555	Shovel, Reversible Point		0.95	6.40
11556	Shovel, 2-1/4"		0.85	6.10
11557	Shovel, 4" "Duckfoot"		1.10	9.70
11558	Shovel, 7"		1.60	11.10
11559	Shovel, 9"		1.85	11.50
20115	S-Tine, 7/16 x 1-1/4 x 12 HD & Clamp for 2" sq toolbar		9.7	40.00
20136	S-Tine, 7/16 x 1-1/4 x 16 HC & Clamp for 2-1/2" sq toolba both include Fasteners for Shovel / Shovel sold separately		12.2	59.00

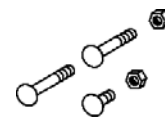
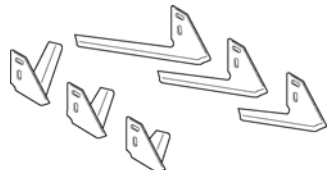
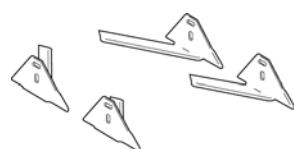
REPLACEMENT & ACCESSORY

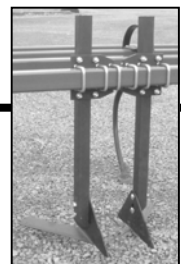
Part No	Description		Wt.	Retail.Price
20155-33	D5-Clamp Asby, 2sq x 1-1/2sq		3.0	26.00
25155-33	D5-Clamp Asby, 2-1/2sq x 1-1/2sq			31.00
14805	Square Shank 1-1/2" square x 24" total length two 3/8" holes - 1-3/4" spacing		6.6	34.50
00027FA	Bag of Fasteners for Shovel - (1) 3/8-16 x 1 carriage bolt, (1) 3/8-16 x 2 carriage bolt, (1) 3/8-16 x 2-1/4 carriage bolt & (2) 3/8 hex nut			2.00
17624	Beet Sweep, 5" Left	 a.k.a. Johnson Hoes or Beet Knives	2.6	18.00
17625	Beet Sweep, 5" Right		2.6	18.00
13656	Beet Sweep, 9" Left		Ask	
13657	Beet Sweep, 9" Right		Ask	
13684	Beet Sweep, 13" Left		Ask	
13685	Beet Sweep, 13" Right	Ask		
19371	Tender Hoe, 7" Left		2.5	17.00
19372	Tender Hoe, 7" Right		2.5	17.00
19393	Tender Hoe, 9" Left		Ask	
19394	Tender Hoe, 9" Right		Ask	
15108	Crescent Hoe, Left			12.00
15109	Crescent Hoe, Right			12.00
20142	Square Shank & Clamp for 2" sq toolbar		9.0	46.00
25142	Square Shank & Clamp for 2-1/2" sq toolbar both include Fasteners for Sweeps & Knives Sweeps & Knives sold separately			47.00

REPLACEMENT & ACCESSORY

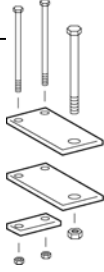
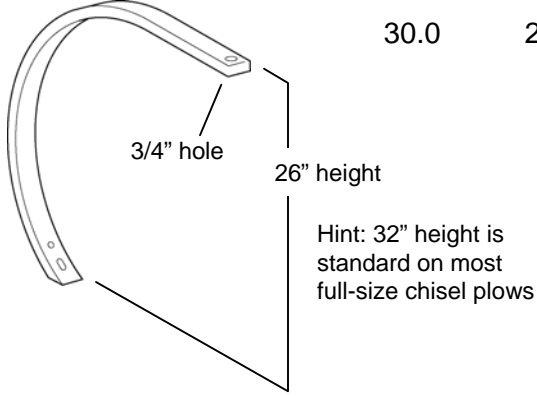
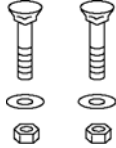
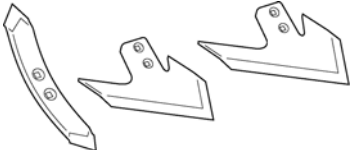
Part No	Description		Retail Price	
30203	Chisel Shank Clamp, 3sq			47.00
40203	Chisel Shank Clamp, 4sq			51.00
18178	Chisel Shank - 1 x 2 material x 26" height - Brillion #6D283			NA
18439	Chisel Shank - 1-1/8 x 2 x 26" height		30.0	249.00
00043FA	Bag of Fasteners - to install Chisel Point or Sweep includes (2) 1/2 x 2-1/2 plow bolt w/ washers and nuts			3.00
17841	Chisel Point		5.2	36.00
18239	Chisel Sweep, 10"			30.00
18459	Chisel Sweep, 12"			33.00

REPLACEMENT & ACCESSORY

Part No	Description	Weight	Retail.Price
17179	Ripper Point - 1-1/2 wide x approx 6" long "crimp" both sides of boot behind the slot to secure ripper point to foot - no fasteners	1.7	25.00
18589	Ripper Point, 2" wide x approx 9-1/2" long	6.5	48.00
10875	Roll Pin, 3/8 x 2		0.60
19353	Lifter Sweep, Left	5.4	64.00
19354	Lifter Sweep, Right	5.4	64.00
00031FA	Bag of Fasteners - to install lifter sweep includes (2) 1/2 x 2 hex capscrew w/ nuts and (1) spacer plate		5.00
17461	Lifter Sweep, Left		NA
17462	Lifter Sweep Right		NA
17187C	Ripper Foot - WELD ON	2.8	13.00

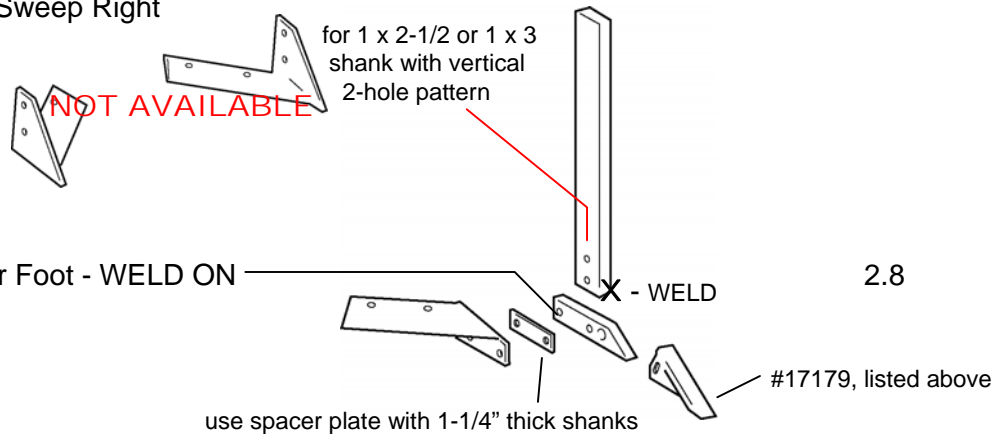
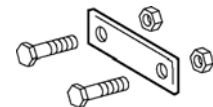
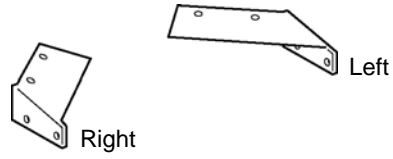

BED LIFTERS

REPLACEMENT

Part No	Description	Weight	Retail.Price
19742-36	Bed Lifter Blade Asby, 36"		360.00
19742-42	Bed Lifter Blade Asby, 42"		392.00
19742-48	Bed Lifter Blade Asby, 48"		408.00
19742-54	Bed Lifter Blade Asby, 54"		416.00
19742-60	Bed Lifter Blade Asby, 60"		440.00
121936	Lifter Blade Only, 36"	30.0	310.00
121942	Lifter Blade Only, 42"	35.0	330.00
121948	Lifter Blade Only, 48"	40.0	350.00
121954	Lifter Blade Only, 54"	45.0	360.00
121960	Lifter Blade Only, 60"	50.0	380.00
19900	Tooth		8.00
10784	Plow Bolt, 7/16-14 x 1-1/4		1.35
11007	Hex Nut, 7/16-14		0.20

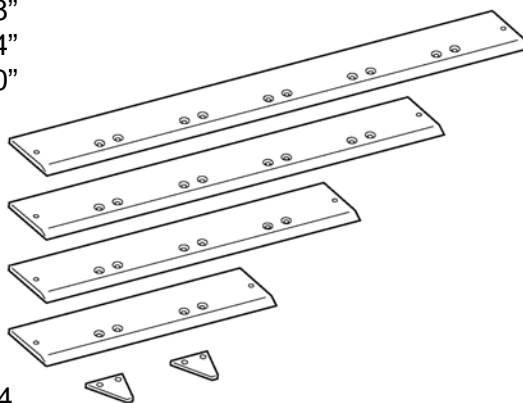

WINDERS

ACCESSORY

Part No	Description	Weight	Retail.Price
16255	Spool, 18 diameter x 12 wide		26.00
16304	Spool, 18 diameter x 20 wide	4.5	28.00
16304	Spool, 18 diameter x 20 wide - lot of 25 (price each)		25.00

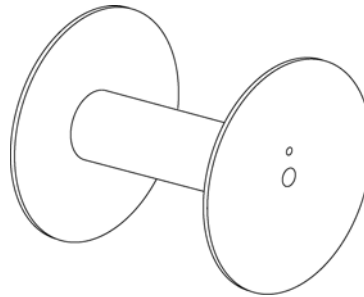
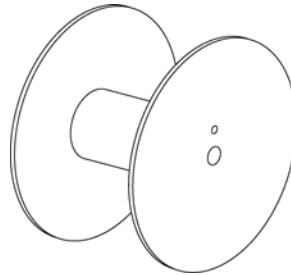

WHEEL ASSEMBLIES

REPLACEMENT

Part No	Description	Retail Price
15392	Bearing, 3/4 ID - <i>quantity (2) each wheel asby</i> 	0.09 7.00
16604	Wheel Asby, 400 x 6 Smooth for 1023 - 1323N - 1723 - 1923 2113 - 2123 - 2133 - 2233 - 2333 - 4133 1512N - 1912 - 2112 - 2212 - 2412 - 4412 	120.00
15001	Wheel Asby, 480/400-8 Smooth for 4333 - 4612 	CALL
18938 18411	Wheel Asby, 410/350-4 ball bearing 5/8 Wheel Asby, 11x400-4 ball bearing 3/4 Wheel Asby, 11x400-5 ball bearing 3/4	90.00
16604 15001	Wheel Asby, 400-6 ball bearing 3/4 Wheel Asby, 480/400-8 ball bearing 3/4 	3.8 120.00 CALL
17813 17815	Wheel Asby, 13x650-6 ball bearing 3/4 Wheel Asby, 15x600-6 ball bearing 3/4	123.00 7.8 127.00
17816	Wheel Asby, 16x650-8 ball bearing 1"	
18447 17166	Wheel Asby, 16x650-8 4-bolt Wheel Asby, 18x850-8 4-bolt	150.00 16.0 CALL
15045	Wheel Asby, 20.5x8-10 5-bolt	CALL